



S-500 / S-500L Snow Machine User Manual



CONFORMS TO
ANSI/UL STD. 73
CERTIFIED TO
CAN/CSA STD.
C22.2 NO.68



English • Français • Deutsch • 中文

© 2021 Antari Lighting and Effects Ltd.

SILENT SNOW MACHINE **S-500** *User Manual*

Safety Information



Please read the following safety information carefully before operating the machine. This information includes important safeguards about installation, usage, and maintenance. Pay attention to all warning labels and instructions in this manual and printed on the machine.

If you have questions about how to operate the machine safely, please contact your local Antari dealer for help.

- Keep this device dry.
- Always connect to a grounded circuit to avoid risk of electrocution.
- Before connecting the machine to power, always check the voltage indicated on the machine matches to your local AC voltage. Do not use the machine if the AC power voltage does not match.
- Disconnect the machine from AC power before servicing and when not in use.
- This product is for indoor use only! Do not expose to rain or moisture. If fluid is spilled, disconnect AC power and clean with a damp cloth. If fluid is spilled onto electronic parts, immediately unplug the machine and contact your local Antari dealer for advice.
- No user serviceable and modifiable parts inside. Never try to repair this product, an unauthorized technician may cause damage or malfunction to the machine.
- For adult use only. Never leave the machine running unattended.
- Install the machine in a well-ventilated area. Provide at least 50 cm of space around the machine.
- Never add flammable liquid of any kind to the machine.
- Make sure there are no flammable materials close to the machine while operating.
- Only use Antari fluid. Other fluid may lead to a heater clog and malfunction.
- If the machine fails to work, unplug the machine and stop operation immediately. Contact your local Antari dealer for advice.

- Before transporting the machine, make sure the fluid tank is completely drained.
- Snow fluid may present health risks if swallowed. Do not drink snow fluid. Store it securely. In case of eye contact or if fluid is swallowed, immediately look for medical advice.
- This appliance must be grounded. In the event of malfunction or breakdown, grounding provides a path of least resistance for electric current to reduce the risk of electric shock. This appliance is equipped with a cord having an equipment-grounding conductor and a grounding plug. The plug must be plugged into an appropriate outlet that is properly installed and grounded in accordance with all local codes and ordinances.

DANGER – Improper connection of the equipment-grounding conductor can result in a risk of electric shock. Check with a qualified electrician or serviceman if the grounding instructions are not completely understood, or if in doubt as to whether the appliance is properly grounded. Do not modify the plug provided with the appliance – if it will not fit the outlet, have a proper outlet installed by a qualified electrician

IMPORTANT SAFETY INSTRUCTIONS

WARNING – When using electric appliances, basic precautions should always be followed, including the following

- a) Read all the instructions before using the appliance
- b) To reduce the risk of injury, close supervision is necessary when an appliance is used near children.
- c) Do not contact moving parts.
- d) Only use attachments recommended or sold by the manufacturer.
- e) Do not use outdoors.
- f) For a cord-connected appliance, the following shall be included:
 - To disconnect, turn all controls to the off (“O”) position, then remove plug from outlet.
 - Do not unplug by pulling on cord. To unplug, grasp the plug, not the cord.
 - Unplug from outlet when not in use and before servicing or cleaning.
 - Do not operate any appliance with a damaged cord or plug, or after the appliance malfunctions or is dropped or damaged in any manner. Return appliance to the

nearest authorized service facility for examination, repair, or electrical or mechanical adjustment.

- g) For a portable appliance – To reduce the risk of electrical shock, do not put in water or other liquid. Do not place or store appliance where it can fall or be pulled into a tub or sink.
- h) For a grounded appliance – Connect to a properly grounded outlet only. See Grounding Instructions.

GROUNDING INSTRUCTIONS

This appliance must be grounded in the event of malfunction or breakdown, grounding provides a path of least resistance for electric current to reduce the risk of electric shock. This appliance is equipped with a cord having an equipment-grounding conductor and a grounding plug. The plug must be plugged into an appropriate outlet that is properly installed and grounded in accordance with all local codes and ordinances.

DANGER – Improper connection of the equipment-grounding conductor can result in a risk of electric shock. The conductor with insulation having an outer surface that is green with or without yellow stripes is the equipment-grounding conductor. If repair or replacement of the cord or plug is necessary, do not connect the equipment-grounding conductor to a live terminal. Check with a qualified electrician or servicemen if the grounding instructions are not completely understood, or if in doubt as to whether the appliance is properly grounded. Do not modify the plug provided with the appliance. If it will not fit the outlet, have a proper outlet installed by a qualified electrician.

DANGER – improper connection of the equipment-grounding conductor can result in a risk of electric shock. Check with a qualified electrician or serviceman if the grounding instructions are not completely understood, or if in doubt as to whether the appliance is properly grounded. Do not modify the plug provided with the appliance – if it will not fit the outlet, have a proper outlet installed by a qualified electrician.

This appliance is for use on a nominal 120V circuit and has a grounding plug that looks like the plug illustrated in sketch A in Figure 73.1. A temporary adaptor, which looks like the adaptor illustrated in sketches B and C, may be used to connect this plug to a 2 pole receptacle as shown in sketch B if a properly grounded outlet is not available. The temporary adaptor should be used only until a properly grounded outlet can be installed by

a qualified electrician. The green colored rigid ear, lug, and the like, extending from the adaptor must be connected to a permanent ground such as a properly grounded outlet box cover. Whenever the adaptor is used, it must be held in place by the metal screw.

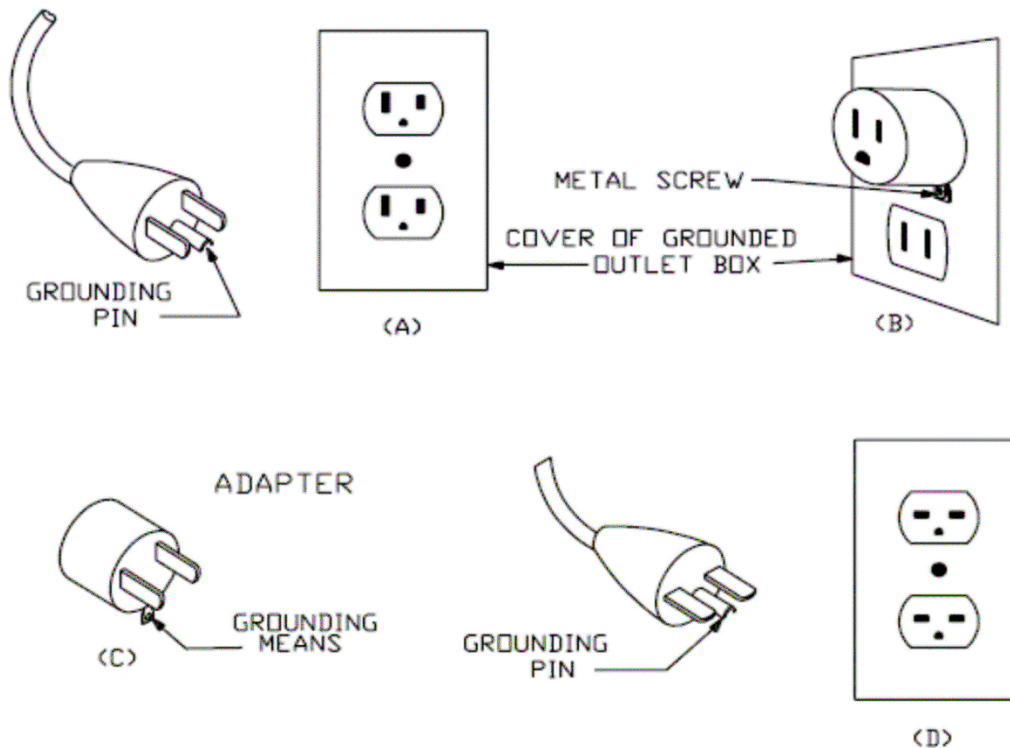

Unpacking and Inspection

Immediately upon receiving the machine, carefully unpack the carton, check the content to ensure that all parts are present and have been received in good condition. If any parts appear damaged or mishandled from shipping, notify the shipper immediately and retain the packing material for inspection.

- What is included:**
- 1 x S-500 Snow Machine
 - 1 x Power Cord
 - 1 x User Manual
 - 1 x Fluid Tank Feed Tube
 - 1 x 20 Liter Fluid Tank
 - 1 x Air Hose 10 Meters for S-500 / 20 Meters for S-500L
 - 1 x Nozzle

Product Dimensions

S-500 Model



S-500L Model



Product Overview



S-500 Control Panel

- Breaker
- Main Power Switch
- Wireless Antenna
- Control Panel



Tank Capacity: 20 liters

Nozzle



XLR 3-Pin DMX Connector

XLR 5-Pin DMX Connector

Neutrik PowerCon

SC-3 Remote Control (Optional)



PM-1 Pan Motor (Optional)

Setting Up

Step 1: Place the machine on a flat surface and in a suitably large area with at least 50 cm open space around the machine.

Step 2: Fill the fluid tank with Antari approved fluid.

Step 3: Connect the machine to a suitably rated power supply. To determine the power requirement for the machine refer to the label on the back of the machine.



Always connect the machine to a protected circuit and ensure it is properly grounded to avoid risk of electrocution.

Step 4: Turn on the machine, press the [VOLUME]/[DOWN] button on the control panel to start making snow.

Step 5: To turn off the machine, press the [STOP] button and put the power switch to the **OFF** position.

Operation

Control Panel Operation

The machine can be operated with onboard digital control interface

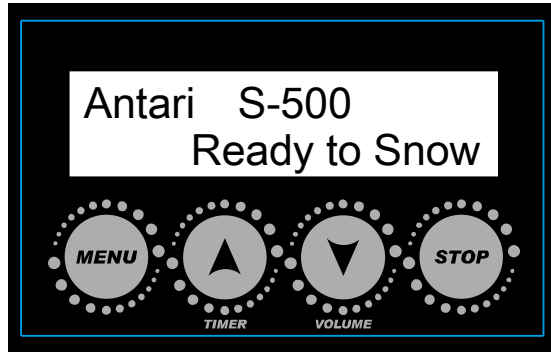

Button	Function
[MENU]	Scroll through setting menu
[UP]/[TIMER]	Up/Activate Timer function
[DOWN]/[VOLUME]	Down/Activate Volume function
[STOP]	Deactivate Timer/Volume function, Escape from menu

Language Setting

To switch the language used for the control interface, press the [Menu] button BEFORE turning on the machine and HOLD it until the LCD screen flashes twice. After the two flashes, press [Menu] to choose the language: English and 中文 (Chinese). After choosing the desired language, press [STOP] to memorize the setting.

Control Menu

Timer Interval XXX Sec	Set interval time at timer mode from 15 to 360 sec
Timer Duration XXX Sec	Set duration time at timer mode from 5 to 120 sec
Timer Output XXX %	Set output volume in Timer mode between 1 and 100 %
Volume Output XXX %	Set output volume in Volume mode between 1 and 100 %

Fan Speed
XXX %

Set fan speed from 20 to 100%

DMX-512
Address: XXX

Set DMX/W-DMX address from 1 to 511

W-DMXPower
XX

Turn On/Off W-DMX function

W-DMX Reset
XX

Unlink from a W-DMX transmitter

Wireless
XX

Turn On/Off wireless remote feature

Wireless Register
Up:Pair Down:Del

Pair/unpair wireless remote.

*This menu will not be shown when Wireless is turned off.

Run Last Setting
XX

Turn On/Off run last setting function

DMX Connector Pin Assignment

The machine provides a 3- or 5-pin XLR connector for DMX connection. The diagram below indicates pin assignment information.

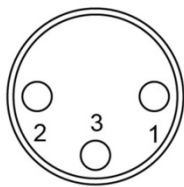

3 Pin XLR

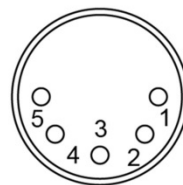
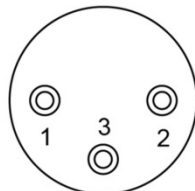

5 Pin XLR

Pin	Function
1	Ground
2	Data-
3	Data+

DMX Operation

Making the DMX Connection – Connect the machine to a DMX controller or to one of the machines in the DMX chain. The machine uses a 3-pin XLR connector for DMX connection, the connector is located on the rear of the machine.



Address Setup – Use control menu to set DMX address. The machine occupies 2 control channels. The starting address is defined as the first channel from which the machine will respond to the controller. Always double check to make sure there are no overlapping channels in order to control the machine correctly.

DMX Channel Function

Channel 1	DMX Value Range	Function
Snow Output Level	0 – 5	Snow off
	6 – 255	Snow Output 1 – 100%
Channel 2	DMX Value Range	Function
Fan Output Level	0 – 5	Fan 20%
	6 – 255	Fan 21 – 100%

WTR-20 Wireless Remote Kit Operation

Wireless remote control system W-2 consists of a transmitter equipped with two buttons to activate, deactivate and adjust output level; with an onboard receiver attached to the front panel of S-500 snow machine.



W-2 Wireless Transmitter



Wireless Receiver

Button	Function
[A]	Activate output
[B]	Deactivate output
[C]	Increase output level
[D]	Decrease output level

In a free open space the effective distance is 50 meters, actual usage depends on obstacle level; the effective distance is 10-25 meters.

Registering a transmitter

Transmitters can be paired or deleted from the receiver. Each receiver can pair up to 10 transmitters. Follow below diagram to pair or delete transmitter.

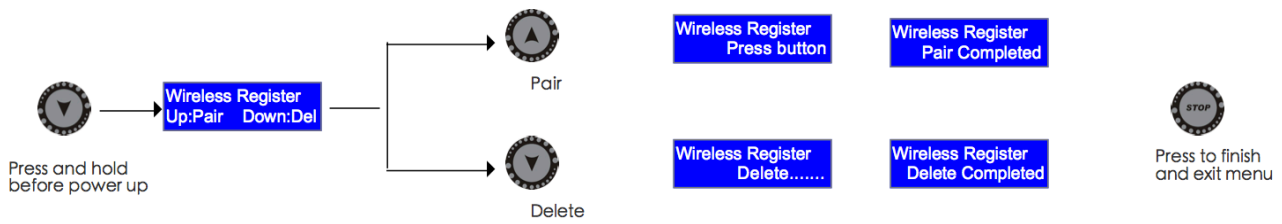

IMPORTANT NOTE: *Wireless register menu will only be shown when Wireless is turn ON*
Transmitter battery replacement

If the effective distance seems to decrease, it is possible the battery level is low and requires replacement. In order to replace the battery, undo the three screws on the back of transmitter to release the cover. Replace with same type and specification of battery which is 27A 12V.

SC-3 Wire remote Operation (Optional)

Wired remote control module SC-3 enables to control the machine from a remote location. With three push buttons and two rotary knobs to activate/deactivate, priming and output level adjustment.



Button/Knob	Function
[TOP LEFT KNOB]	Adjust pump output level
[TOP RIGHT KNOB]	Adjust blower output level
[LEFT BUTTON]	Max output on pump and blower
[CENTER BUTTON]	Turn On/Off SC-3 remote
[RIGHT BUTTON]	Max output on blower

IMPORTANT NOTE:

[LEFT BUTTON] is meant for priming use, with a new tank of fluid or refill the fluid may not pump properly due to airlock in the pipeline, use this function to activate pump at maximum

output, the [RIGHT BUTTON] is used when needed to clean out residue at the tip of output nozzle. Both of these buttons will overtake output adjustment knobs.

Physical Installation

Important

- Use supplied mounting bracket or rigging clamp to install nozzle.
- Make sure installation location, fastening connecting, and rigging hardware can hold at least 10 times the weight of the nozzle.
- Make sure no combustible or flammable materials are nearby.
- Secure nozzle with an approved safety cable that can hold at least 10 times the weight of nozzle.
- Make sure nozzle is installed in a well ventilated area.
- Consider nozzle replacement and routine maintenance access when selecting installation location.

Adjustable Mounting Bracket

Adjust mounting bracket by loosening screws, set the nozzle to desired angle and tighten the screw to finish adjustment. Illustration below demonstrates how to adjust mounting bracket.

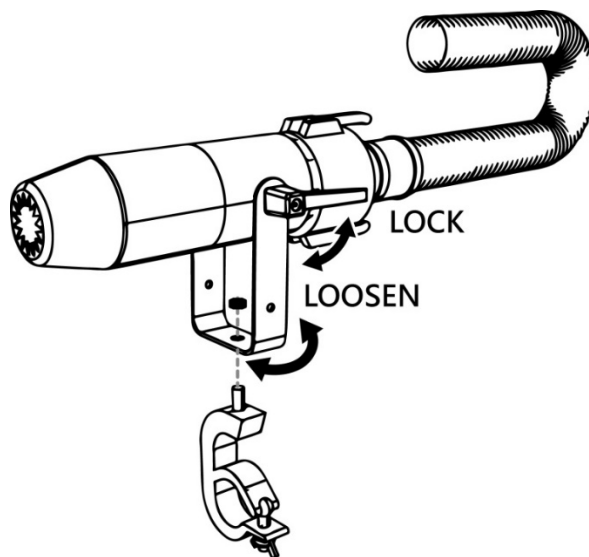

Mounting

Use screws for surface mounting or clamps for truss mounting.

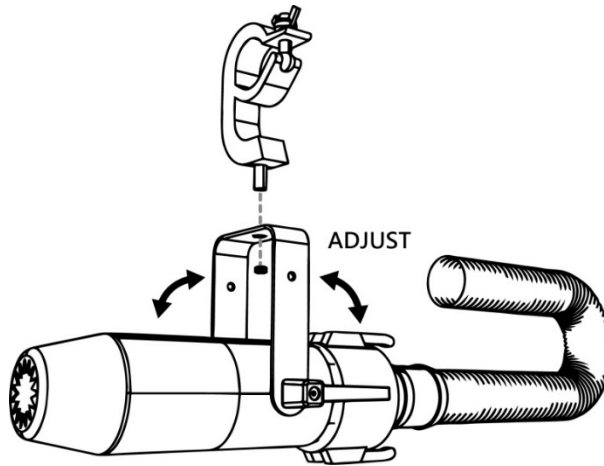

ST-10 Air Hose Extension (Optional)

The maximum air hose length is 20 meters. Illustration below demonstrates how to connect extension air hose.

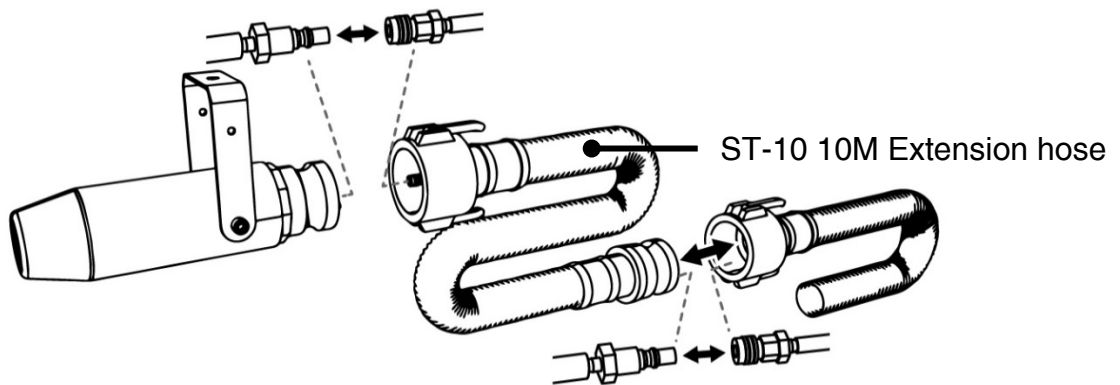

Status of W-DMX Connection (Optional)

Symbol on the Liquid Crystal Display	Status of W-DMX connection
○	Transmitter not assigned
◎	Transmitter assigned, No DMX signal
◉	Transmitter link lost or linking to transmitter
●	Transmitter assigned, DMX signal received

Fluid

Only use Antari SL-5/SL-5A/SL-5N/SL-5AN liquid for the S-500 Snow Machine. The machine is tested and calibrated with this liquid to get the best output performance. Warranty will be void if any other type of liquid is used, improper use of liquid may lead to machine failure and malfunction.

Service and Maintenance

- Do not allow the machine to become contaminated.
- Remove dust from air vents with air compressor, vacuum or a soft brush.
- Only use a damp cloth to clean the casing.
- Before storing run distilled water through the system to help avoid condensing the pump or heater.
- It is recommended to run the machine on a monthly basis in order to achieve best performance and output condition.
- Excessive dust, liquid and dirt built up will degrade performance and cause overheating.
- Before storing away after operation, pump pure water through the system for at least 1 to 2 minutes. This will help clean out the remaining snow fluid and prevent pump from malfunction on next usage.

Breaker Reset



Disconnect AC power before resetting the breaker. Only replace fuse with same type and rating.

Step 1: Disconnect power cord from supply.

Step 2: Flip breaker to ON position.

Step 3: Turn on machine for testing.

Breaker

120V = 10A 250V

240V = 5A 250V

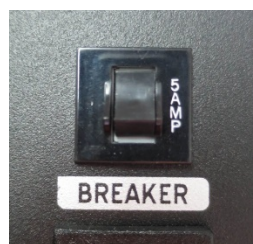

Technical Specifications

S-500

- Input voltage US model :AC 100-120V, 50 / 60HZ 7.5A
 EU model :AC 220-240V, 50 / 60Hz 3.8A
- Rated power 900 W
- Fluid consumption 400 ml/min
- Fluid tank capacity 20 Liters (5.28gal)
- Compatible fluid Antari SLN Snow Foam Fluid
 Antari SLAN Snow Foam Fluid
 Antari SLH Snow Foam Fluid
 Antari SLC Snow Foam Fluid
- Ambient temp.range 5°C - 40°C (41°F - 104°F)
- Control Manual, Timer, DMX 512
 Wireless (Optional), Wireless DMX (Optional)
- DMX channels 2 channels
- Connection Neutrik Powercon(Power)
 XLR 3-pin and 5-pin (DMX)
- Optional Accessories W-DMX-PCBR Wireless DMX 512
 WTR-20 Wireless Remote
 WTR-70 Wireless DMX 512 and Remote
 WTR-80 Wireless Remote
 WTR-90 Wireless DMX
 SC-3 Cable Remote
 ST-10 10 Meter Extension Hose
 PM-1 Pan Motor
- Dimension L592 W551 H651 mm
 (L23.31 W 21.69 H 25.63 inch)"
- Weight 37.2 kg (82.01 lbs)

S-500L

- Dimension L803 W603 H651 mm
 (L31.61 W23.74 H25.63 inch)
- Weight 46.4 kg (102.29 lbs)

SILENT SNOW MACHINE **S-500**

Mode d'emploi

Notices de sécurité



En vue d'utiliser correctement votre nouvel appareil, veuillez lire attentivement ce mode d'emploi. Pour assurer la longévité et le bon fonctionnement de votre machine à fumée, veuillez lire attentivement les instructions suivantes concernant le maniement, la sécurité et l'entretien. Veuillez suivre toute instruction de sécurité appliquée sur le boîtier de votre machine à neige Antari.

Si vous avez des questions sur l'usage de la machine en toute sécurité, contactez votre revendeur Antari.

- Protéger de l'humidité.
- Utilisez uniquement des prises de courant à terre à 3 broches.
- Avant la première mise en marche, assurez-vous que l'appareil soit branché à l'alimentation correcte. Ne jamais utiliser la machine quand la voltage n'est pas correcte.
- Débranchez l'appareil du secteur avant d'entretien ou quand vous n'utilisez pas la machine.
- L'appareil a été conçu pour un emploi dans des locaux clos. Protéger de l'humidité. En cas de projection de liquide, débranchez l'appareil du secteur et nettoyez avec un chiffon humide. Si du liquide devait pénétrer à l'intérieur de l'appareil, débranchez le immédiatement et contactez un technicien ou votre revendeur Antari avant de le réutiliser.
- A l'intérieur de l'appareil, il n'y a aucune partie qui ait besoin d'être révisée. Ne jamais essayer de réparer le produit parce qu'il détruirait la machine.
- L'usage de cet appareil n'est prévu que pour les adultes. Ne jamais faire marcher sans surveillance.
- Installez l'appareil à un endroit bien aéré. Pour garantir une aération suffisante, laissez un espace libre de 50 cm tout autour de l'appareil.

- Ne jamais mélanger des liquides inflammables gazeux ou huileux avec le liquide à fumée.
- Respectez une distance minimum de 50 cm entre le bec de la machine et les matériaux inflammables.
- Employez uniquement des liquides à neige de haute qualité à base d'eau Antari ou liquides recommandée par votre revendeur. D'autres liquides à fumée pourraient causer des problèmes d'encrassement ou des crachotements.
- Si votre machine à fumée Antari ne devait plus fonctionner correctement, éteignez le immédiatement. S'il vous plaît contactez votre revendeur Antari.
- Faites attention à ce que le réservoir soit toujours complètement vidé avant d'envoyer ou transporter l'appareil.
- Ne jamais avaler le liquide à fumée. Stocker avec prudence. Si c'était tout de même le cas, consultez un médecin immédiatement.

Déballage & inspection

Ouvrez le carton extérieur et assurez vous que toutes les pièces n'aient subi aucun dommage durant leur transport. En cas de livraison endommagée ou incomplète, toujours contactez immédiatement votre revendeur Antari.

Contenu de la livraison : 1 x S-500 Machine à neige

1 x Câble d'alimentation

1 x Mode d'emploi

1 x Flexible de remplissage

1 x Réservoir 20 litres

1 x Tuyau 10 metres (S-500) / 20 metres (S-500L)

1 x Bec

Dimensions du produit

S-500 Model



S-500L Model



Descriptif du produit



Panneau de contrôle

Disjoncteur

Commutateur secteur

Antenne

Panneau de contrôle

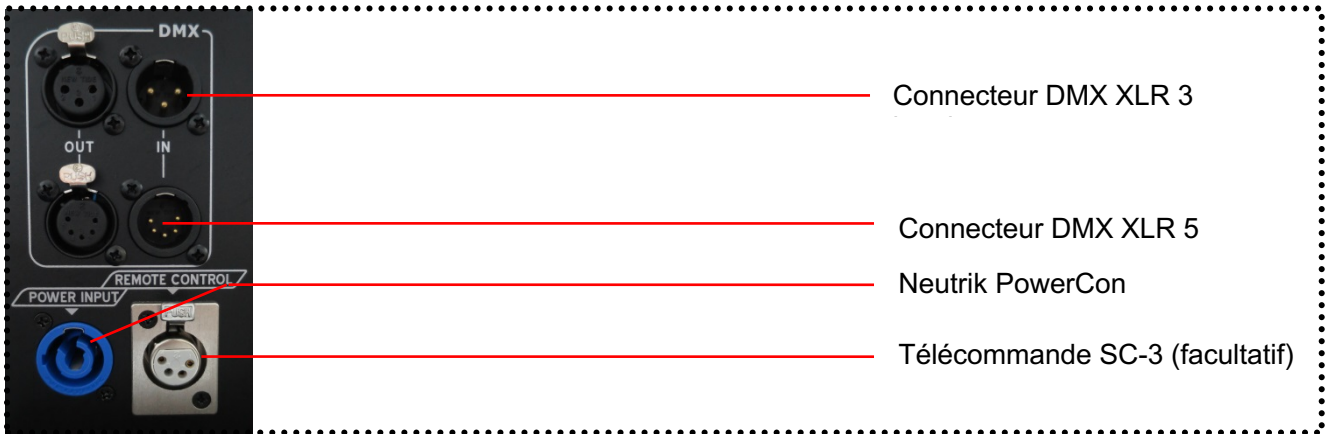
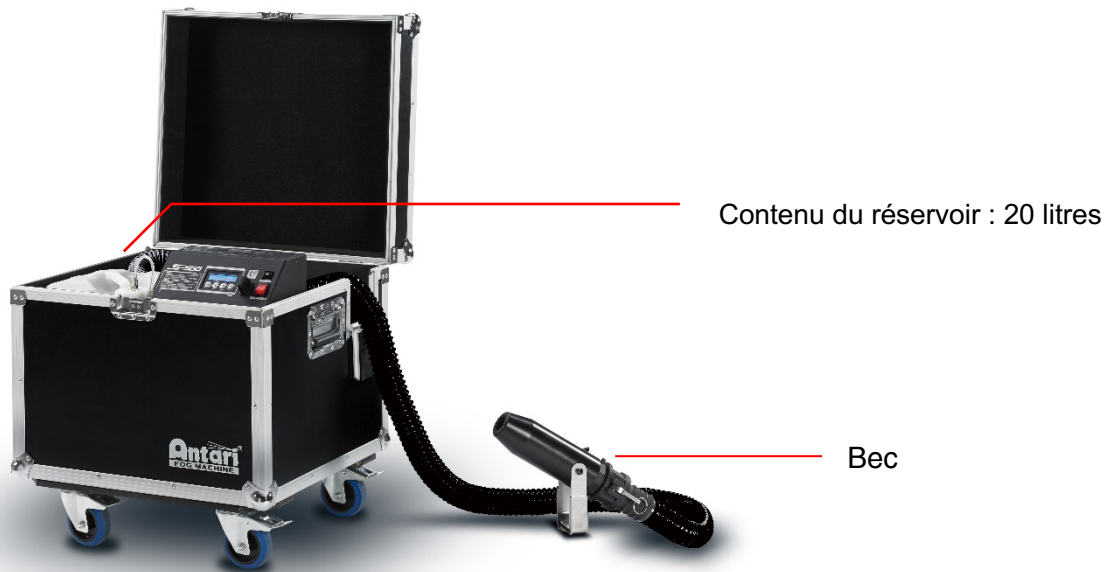

Mise en service

Etape 1 : Positionnez la machine sur une surface plane avec au moins 50cm d'espace libre tout autour.

Etape 2 : Remplissez le réservoir avec un liquide approprié.

Etape 3 : Branchez la fiche d'alimentation dans une prise de courant avec terre. Veuillez voir l'affichage du type pour chercher l'information sur l'alimentation.



Reliez l'appareil à la terre afin d'éviter tout risque de choc électrique.

Etape 4 : Mettez la machine en service . Pour activer le débit de neige, appuyez sur le bouton [VOLUME]/[DOWN] sur le panneau de contrôle.

Etape 5 : Mettre la machine hors de service avec le bouton **Stop** et mettez le commutateur d'alimentation OFF.

Opération

Panneau de Contrôle

Vous pouvez contrôler l'appareil avec le panneau de contrôle intégrée.



Bouton	Fonction
[MENU]	Permet d'accéder aux différents menus
[UP]/[TIMER]	Pour augmenter une valeur ou choisir entre options /

	Pour activer le mode Timer
[DOWN]/[VOLUME]	Pour diminuer une valeur / Pour activer le mode continu
[STOP]	Pour inactiver le débit de neige

Réglage de menu

<p>Timer Interval XXX Sec</p>	Réglage de l'intervalle entre 15 et 360 secondes.
<p>Timer Duration XXX Sec</p>	Réglage de la durée entre 5 et 120 secondes.
<p>Timer Output XXX %</p>	Réglage du volume de neige entre 1 et 100 %.
<p>Volume Output XXX %</p>	Réglage du volume de neige entre 1 et 100 % ou fumée continue.
<p>Fan Speed XXX %</p>	Détermine la vitesse du ventilateur de 20 à 100 %.
<p>DMX-512 Address: XXX</p>	Réglage de l'adresse DMX/W-DMX entre 1 et 511.
<p>W-DMX Power XX</p>	Allume/eteint le W-DMX.
<p>W-DMX Reset XX</p>	Débrancher d'un émetteur W-DMX.
<p>Wireless XX</p>	Allume/eteint la fonction sans fil.

Wireless Register
Up:Pair Down:Del

Connecter / déconnecter un transmetteur sans fil.

*La fonction Wireless Register peut seulement être utilisée si la fonction sans fil est activée.

Run Last Setting
XX

Allume / Eteint le lancement des dernières fonctions enregistrées

Configuration de la connexion DMX

La machine possède fiches XLR 3 et 5 pôles pour connecter un contrôleur DMX. Le graphique ci-dessous montre la configuration des fiches.

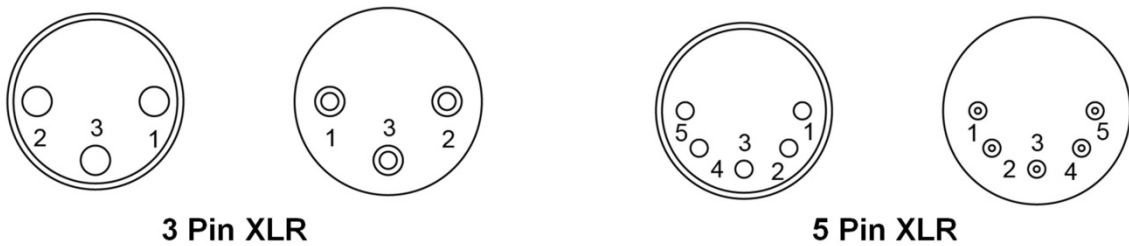

Contact	Fonction
1	Masse
2	Signal-
3	Signal+

Operation DMX

Connexion DMX – Connectez la machine à un contrôleur DMX ou une machine dans la chaîne DMX. Pour la connexion DMX, les raccords XLR 3 et 5 pôles se trouvent au derrière de la machine.



Réglage de l'adresse - Utilisez la fonction DMX-512 Address dans le menu afin d'attribuer

les adresses DMX. La machine peut être réglé par deux canaux DMX. L'adresse de départ est déterminée sur le 1er canal détecté par le contrôleur. Assurez-vous que les canaux de se superposent pas afin que la machine fonctionne correctement.

Fonctions DMX

Canal 1	Valuers DMX	Fonction
Volume d'émission	0 – 5	arrêt (aucun dégivage de neige)
	6 – 255	Volume de neige 1 – 100%
Canal 2	Valuers DMX	Fonction
Vitesse du ventilateur	0 – 5	Ventilateur 20%
	6 – 255	Ventilateur 21 – 100%

WTR-20 Opération sans fil

La contrôleur sans fil se W-2 compose d'un transmetteur avec deux boutons pour activer le débit de neige et un récepteur fixé au dos de l'appareil.



W-2 transmetteur sans fil



Récepteur sans fil

Bouton	Fonction
[A]	Pour dégager la neige
[B]	Pour inactiver la neige
[C]	Augmenter le volume de neige
[D]	Diminuer le volume de neige

Avec le transmetteur, il est possible de débiter de fumée dedans un rayon d'action de 10-25 mètres (avec ligne de visée).

Registrier transmetteurs

Les transmetteurs peuvent être connectés avec le et déconnectés du récepteur. 10 transmetteurs sans fil peuvent fonctionner en parallèle avec un récepteur. Pour connecter ou déconnecter un transmetteur, veuillez suivre les étapes suivantes.

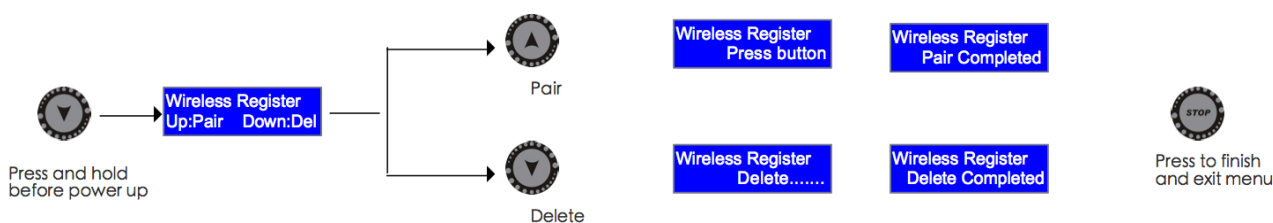

Note importante : La fonction *Wireless Register* peut seulement être utilisée si la fonction sans fil est activée.

Remplacer la Batterie

Si la portée de la télécommande diminue, les batteries sont mortes et doivent être remplacées. Enlever le couvercle sur la face arrière de la télécommande pour éloigner la batterie. On utilise un pile bouton 27A 12V.

SC-3 Télécommande câblée (facultatif)

La télécommande câblée SC-3 permet de contrôler l'appareil à distance. Elle a deux boutons et deux régulateurs rotatifs pour activer/inactiver la neige et régler le volume de neige.



Bouton/Régulateur	Fonction
[Régulateur à gauche]	Régler le volume de la pompe
[Régulateur à droite]	Régler le volume de la ventilateur
[Bouton à gauche]	Volume maximale de la pompe et ventilateur
[Bouton central]	SC-3 marche/arrêt
[RIGHT à droite]	Volume maximale de la ventilateur

Note importante :

Le bouton gauche s'utilise pour faire démarrer la machine à neige sans problème. Au remplissage du liquide à neige, il est possible que la pompe ne fonctionne pas correctement à cause d'air dans la conduite. Utilisez cette fonction pour démarrer la pompe avec le volume maximal. Le bouton droit s'utilise pour nettoyer la pompe de résidus. Les deux boutons sont prioritaires aux régulateurs de débit.

Installation

Notes importantes :

- Utilisez le lyre de fixation fourni ou un crochet pour l'installation du bec.
- Les dispositifs de suspension du bec doivent être construits et conceptionnés de telle manière qu'ils puissent supporter dix fois son charge utile.
- Ne jamais braquer le bec sur des flammes ou sur des objets inflammables.

- Fixer le bec avec une élingue de sécurité qui peut supporter dix fois un charge utile.
- Positionnez toujours l'appareil dans un endroit disposant d'une bonne ventilation.
- Positionnez toujours l'appareil dans un endroit disposant d'espace pour l'entretien.

Lyre de fixation

Pour orienter le lyre, desserrez les vis. Réglez l'inclinaison voulue, puis revissez les vis. Le graphique ci-dessous montre l'orientation de la lyre.

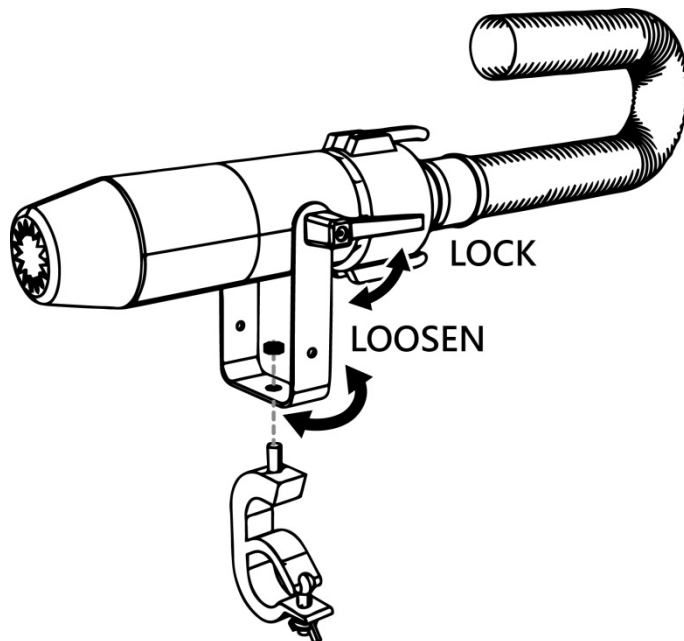

Montage

Utilisez des vis pour le montage en surface ou des crochets pour la montage à une traverse.

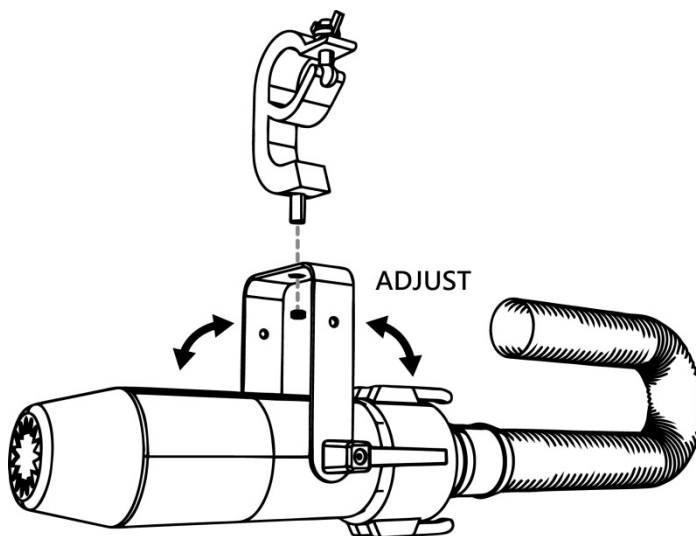

ST-10 Rallonge du tuyau d'air (facultatif)

La longueur maximale du tuyau est de 20 mètres. Le graphique ci-dessous montre le raccord du tuyau.

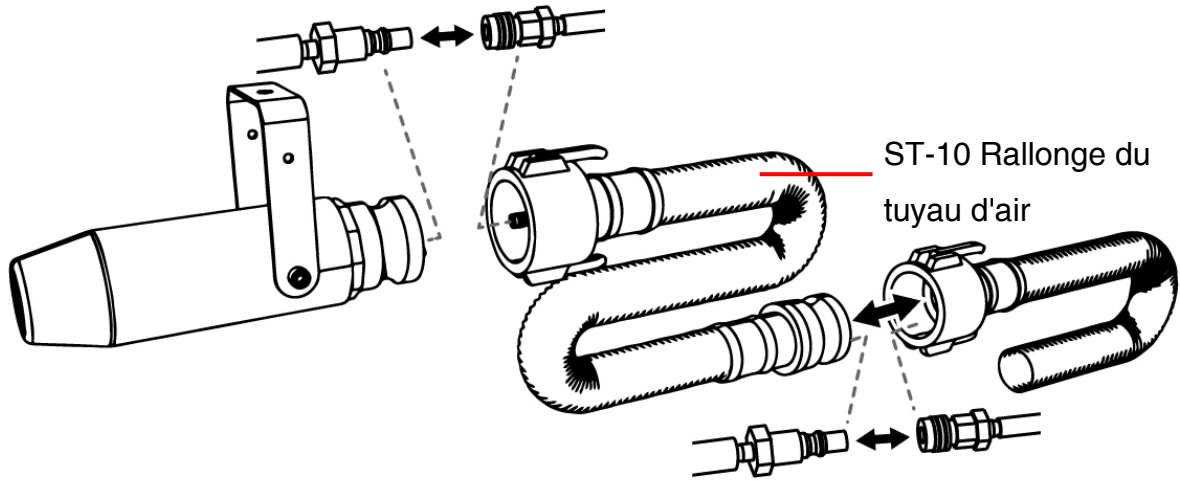

État de la connexion W-DMX (facultatif)

Symbole sur l'écran	État de la connexion W-DMX
●	Transmetteur assigné ; signal DMX reçu
◎	Transmetteur assigné ; pas de signal DMX
⊙	Connexion transmetteur perdue ou transmetteur connectant
○	Transmetteur n'est pas assigné

Liquide

Employez uniquement des liquides à neige Antari SL-5/SL-5A ou liquides recommandée par votre revendeur. La machine est testée avec ce liquide pour la puissance plus haute. Autres liquides peuvent endommager la machine. Des casses causés du fait de l'usage de liquide différent ne sont pas inclus dans la garantie.

Nettoyage et maintenance

- Faites toujours attention de ne pas polluer le liquide à neige.
- Enlevez la poussière des orifices d'aération avec un compresseur d'air, aspirateur ou une brosse tendre.
- Toujours nettoyez la machine avec un chiffon sec.
- Utiliser l'eau distillée pour rincer votre machine avant de l'entreposage.
- Pour une performance optimale, nous vous conseillons de faire fonctionner la machine au moins une fois par mois.
- Poussière, liquide et boue excessive provoquent la surchauffe de l'élément de chauffage.
- Rincez votre machine à neige avec de l'eau distillée avant son entreposage. De cette manière, tous résidus de liquide à neige seront éliminés, et ainsi il n'y aura pas de brouillage de fonction dans la pompe au démarrage prochain.

Remplacer le fusible



Avant le remplacement du fusible débrancher l'appareil. Toujours remplacer un fusible par un autre de modèle identique.

Etape 1 : Débranchez la machine.

Etape 2 : Mettez le disjoncteur en mode "ON".

Etape 3 : Veuillez mettre la machine en service pour tester le fonctionnement.

Disjoncteur

120V = 10A 250V

240V = 5A 250V



Caractéristiques Techniques

S-500

Alimentation	US model : AC 100-120V, 50 / 60Hz 7.5A EU model : AC 220-240V, 50 / 60Hz 3.8A
Puissance de rendement	9000W
Consommation de liquide	400 ml/min
Contenu du réservoir	20 Liters (5.28gal)
Liquide compatible	Antari SLN Snow Foam Fluid Antari SLAN Snow Foam Fluid Antari SLH Snow Foam Fluid Antari SLC Snow Foam Fluid
Température ambiante	5 °C - 40 °C (41 °F-104 °F)
Contrôle	DMX, timer, manuellement Sans fil (facultatif), W-DMX (facultatif)
Canaux DMX	2 canaux
Connexion	Neutrik Powercon (alimentation) XLR 3 pôles et 5pôles (DMX)
Accessoires	W-DMX-PCBR Wireless DMX 512 WTR-20 Contrôleur sans fil WTR-70 W-DMX et télécommande WTR-80 Contrôleur sans fil WTR-90 Wireless DMX SC-3 Télécommande câblée ST-10 Rallonge du tuyau 10 mètres PM-1 Pan Motor
Dimensions	L592 I551 H651 mm (L23.31 I21.69 H25.63 inch)
Poids	37.2 kg (82.01 lbs)

S-500L

Dimensions	L803 I603 H651 mm (L31.61 I23.74 H25.63 inch)
Poids	46.4 kg (102.29 lbs)

SILENT SNOW MACHINE **S-500** *Bedienungsanleitung*

Sicherheitshinweise



Vor Benutzung der Maschine bitte unbedingt diese Bedienungsanleitung sorgfältig lesen. Sie enthält wichtige Informationen zur Sicherheit, Installation, Benutzung und Wartung. Bitte beachten Sie alle Warnhinweise und Anweisungen in dieser Bedienungsanleitung und auf Ihrem Gerät.

Wenden Sie sich an Ihren Fachhändler, wenn Sie Fragen zur sicheren Bedienung des Geräts haben sollten.

- Vor Nässe schützen.
- Verwenden Sie bitte ausschließlich dreiadrige, geerdete Steckdosen, um eine Stromschlaggefahr zu vermeiden.
- Vor Inbetriebnahme darauf achten, dass das Gerät an die richtige Spannung angeschlossen wird. Betreiben Sie das Gerät nicht, wenn die Spannungsangaben nicht übereinstimmen.
- Vor Wartungsarbeiten und nach dem Betrieb trennen Sie bitte das Gerät vom Netz oder schalten es aus.
- Nur innerhalb geschlossener Räume betreiben! Vor Nässe schützen. Sollte Schneeflüssigkeit ausgelaufen sein, trennen Sie das Gerät vom Netz und reinigen Sie es mit einem feuchten Tuch. Sollte Schneeflüssigkeit ins Innere der Maschine gelangen, trennen Sie die Maschine bitte sofort vom Netz. Kontaktieren Sie bitte einen Servicetechniker oder Ihren Antari-Händler, bevor Sie die Maschine erneut benutzen.
- Im Innern der Maschine befinden sich keine vom Benutzer zu wartenden Teile. Wenden Sie sich an Ihren autorisierten Fachhändler für Wartungs- und Servicearbeiten.
- Nur für Erwachsene. Betreiben Sie das Gerät niemals unbeaufsichtigt.
- Betreiben Sie das Gerät in gut belüfteten Räumen. Um eine ausreichende Belüftung zu gewährleisten, halten Sie bitte einen Mindestabstand von etwa 50 cm um und über

dem Gerät ein.

- Mischen Sie niemals entzündliche Flüssigkeiten jeglicher Art (Öl, Gas, Duftstoffe) unter die Schneeflüssigkeit.
- Halten Sie das Gerät während der Benutzung von entflammenden Gegenständen fern.
- Verwenden Sie nur die Antari-Schneeflüssigkeit oder andere hochwertige Flüssigkeiten, die von Ihrem Händler empfohlen wurden. Andere Schneeflüssigkeiten können zum Verstopfen oder zu Beschädigungen des Geräts führen.
- Sollte Ihre Antari-Maschine einmal nicht mehr ordnungsgemäß arbeiten, schalten Sie sie bitte sofort ab. Nehmen Sie bitte mit Ihrem Antari-Händler Kontakt auf.
- Entleeren Sie den Tank immer, bevor Sie das Gerät verschicken oder transportieren.
- Schneeflüssigkeit kann ein Gesundheitsrisiko darstellen, wenn es verschluckt wird. Trinken Sie niemals Schneeflüssigkeit. Bewahren Sie Schneeflüssigkeit sicher auf. Sollten Sie Schneeflüssigkeit verschlucken oder sollten die Haut oder die Augen damit in Berührung kommen, konsultieren Sie bitte sofort einen Arzt.

Auspacken und Prüfen der Maschine

Öffnen Sie nach dem Erhalt der Maschine den Versandkarton und stellen Sie sicher, dass alle Teile, die für den Betrieb des Systems notwendig sind, in einem einwandfreien Zustand eingetroffen sind. Wenn Ausrüstungsteile fehlen oder beschädigt sein sollten, nehmen Sie bitte sofort mit Ihrem Antari-Händler Kontakt auf.

Lieferumfang:	1 x S-500 Schneemaschine
	1 x Netzkabel
	1 x Bedienungsanleitung
	1 x Einfüllschlauch
	1 x 20 Liter Tank
	1 x 10 Meter Schlauch (S-500) / 20 Meter Schlauch (S-500L)
	1 x Düse

Geräteabmessungen

S-500L Model



S-500L Model



Geräteübersicht



S-500 Bedienfeld

- Schutzschalter
- Netzschalter
- Funkantenne
- Bedienfeld



Tankinhalt: 20 Liter

Düse



DMX 3-polig XLR

DMX 5-polig XLR

Neutrik PowerCon

SC-3 Fernbedienung (Zubehör)



PM-1 Motor (Zubehör)

Inbetriebnahme

Schritt 1: Installieren Sie die Maschine auf einer ebenen Oberfläche. Halten Sie bitte einen Mindestabstand von etwa 50 cm um und über dem Gerät ein.

Schritt 2: Füllen Sie den Tank mit Schneeflüssigkeit.

Schritt 3: Stecken Sie den Netzstecker in eine geerdete Schutzkontaktsteckdose ein. Die Angabe des zulässigen Spannungsbereichs finden auf der Rückseite der Maschine.



Verwenden Sie bitte ausschließlich dreiadrige, geerdete Steckdosen, um eine Stromschlaggefahr zu vermeiden.

Schritt 4: Schalten Sie die Maschine ein. Drücken Sie die Taste [VOLUME]/[DOWN] am Bedienfeld, um Schnee auszustoßen.

Schritt 5: Drücken Sie die [STOP]-Taste und stellen Sie den Netzschalter in die Position **OFF**, um die Maschine auszuschalten.

Bedienung

Bedienfeld

Die Bedienung der Maschine erfolgt über das Bedienfeld.

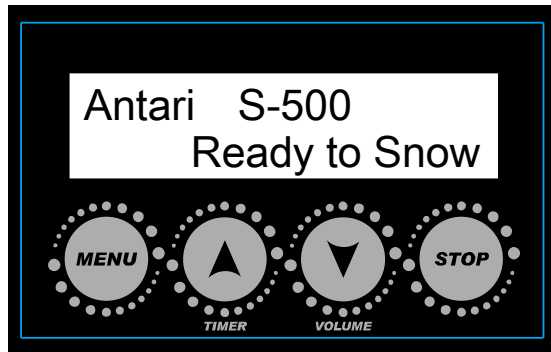

Taste	Funktion
[MENU]	Zum Anwählen von Funktionen
[UP]/[TIMER]	Hoch/Zum Aktivieren des Timer-Betriebs
[DOWN]/[VOLUME]	Runter/Zum Aktivieren des Dauerbetriebs
[STOP]	Zum Stoppen des Timers/Schneeausstoßes, Zurückspringen zum Hauptmenü

Menüeinstellungen

Timer Interval XXX Sec	Zeitintervalle zwischen 15 und 360 Sekunden einstellen.
Timer Duration XXX Sec	Zeitintervalle zwischen 5 und 120 Sekunden einstellen.
Timer Output XXX %	Schneemenge zwischen 1 % und 100 % einstellen.
Volume Output XXX %	Schneemenge zwischen 1 % und 100 % einstellen.
Fan Speed XXX %	Lüftergeschwindigkeit zwischen 20 % und 100 % einstellen.
DMX-512 Address: XXX	DMX/W-DMX-Adresse zwischen 1 und 511 einstellen

W-DMX Power XX	W-DMX ein-/ausschalten.
W-DMX Reset XX	Verbindung mit W-DMX-Sendeeinheit trennen.
Wireless XX	Funkfernbedienung ein-/ausschalten
Wireless Register Up:Pair Down:Del	Funkfernbedienung zuweisen oder trennen *Diese Option wird nur bei aktivierter W-DMX-Funktion angezeigt.
Run Last Setting XX	Mit letzter Einstellung starten ein-/ausschalten.

Belegung der DMX-Anschlüsse

Die Maschine verfügt über 3-polige und 5-polige XLR-Anschlüsse für den DMX-Anschluss. Die nachfolgende Grafik zeigt die Belegung der Buchsen.

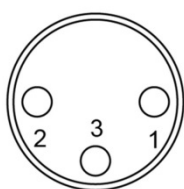

3 Pin XLR

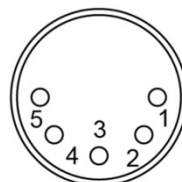
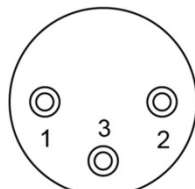

5 Pin XLR

Kontakt	Funktion
1	Masse
2	Signal-
3	Signal+

DMX-Steuerung

DMX-Anschluss herstellen – Schließen Sie die Maschine an einen DMX-Controller oder an ein Gerät in der DMX-Kette an. Für den DMX-Anschluss sind 3-polige DMX-Anschlüsse auf

der Rückseite der Maschine angebracht.



DMX512-Adresse einstellen – Der Adressierung erfolgt über das Bedienfeld. Die Maschine belegt 2 Steuerkanäle. Die Startadresse ist der erste Kanal, auf den die Maschine auf Signale vom Controller reagiert. Achten Sie darauf, dass sich keine Kanäle überlappen, damit die Maschine ordnungsgemäß gesteuert werden kann.

DMX-Steuerfunktionen

Kanal 1	DMX-Wert	Funktion
Ausstoßvolumen	0 – 5	Kein Ausstoß
	6 – 255	Ausstoß 1 – 100%
Kanal 2	DMX-Wert	Funktion
Lüfterleistung	0 – 5	Lüfter 20 %
	6 – 255	Lüfter 21 – 100 %

WTR-20 Funkfernbedienung

Das Funkfernsteuersystem W-2 besteht aus einer Sendeeinheit mit zwei Tasten für den Ausstoß und zur Regulierung sowie einer Empfängereinheit, die an der Maschine angebracht ist.



W-2 Sendeeinheit



Funkempfänger

Taste	Funktion
[A]	Ausstoß aktivieren
[B]	Ausstoß deaktivieren
[C]	Ausstoßmenge erhöhen
[D]	Ausstoßmenge verringern

Mit der Sendeeinheit lässt sich der Ausstoß per Funkübertragung über eine Distanz von bis zu 50 Metern auslösen (Freiluftstrecke); die durchschnittliche Reichweite liegt zwischen 10 und 25 Meter.

Sendeeinheiten zuweisen

Sendeeinheiten lassen sich dem Empfänger zuweisen und wieder trennen. Jeder Empfänger kann von bis zu 10 Sendeeinheiten gesteuert werden. Befolgen Sie die nachfolgenden Anweisungen zum Zuweisen/Trennen einer Sendeeinheit.

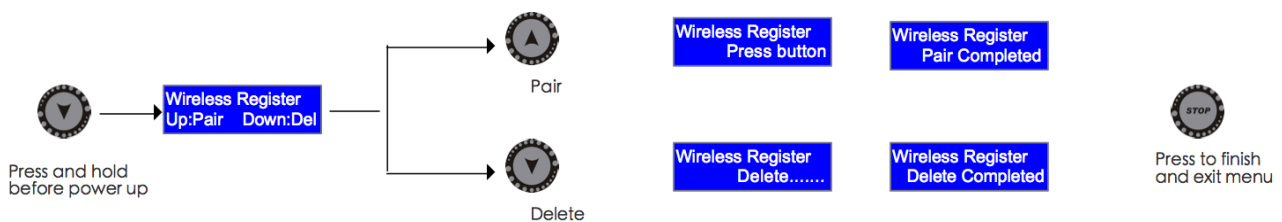

WICHTIGER HINWEIS: Die Option Sendeeinheit zuweisen wird nur bei aktivierter W-DMX-Funktion angezeigt.

Batteriewechsel am Sender

Lässt die Reichweite des Senders nach, ist wahrscheinlich die Batterie verbraucht und muss ausgewechselt werden. Schrauben Sie dazu die Gehäuseabdeckung ab und

entfernen Sie die verbrauchte Batterie. Legen Sie eine frische Batterie (27 A, 12 V) wie im Batteriefach angegeben ein und schrauben Sie die Gehäuseabdeckung wieder an.

SC-3 Kabelfernbedienung (Zubehör)

Mit der Fernbedienung SC-3 lässt sich die Maschine bequem aus der Distanz steuern. Sie verfügt über 2 Drehregler zum Aktivieren/Deaktivieren des Ausstoßes und zum Einstellen der Ausstoßmenge.



Taste/Regler	Funktion
[Linker Regler]	Pumpleistung einstellen
[Rechter Regler]	Gebälseleistung einstellen
[Linke Taste]	Maximale Pump- und Gebläseleistung
[Mittlere Taste]	SC-3 Fernbedienung ein-/ausschalten
[Rechte Taste]	Maximale Gebläseleistung

WICHTIGER HINWEIS:

Die [Linke Taste] dient zum Ansaugen. Beim Auffüllen der Schneeflüssigkeit kann es sein, dass die Pumpe nicht korrekt arbeitet, da sich Luft in der Leitung befindet. Verwenden Sie diese Funktion, um die Pumpe mit maximaler Leistung zu betreiben. Mit der [rechten Taste] lässt sich die Düse von Rückständen befreien. Beide Tasten haben Vorrang vor den Ausstoßreglern.

Montage

Wichtig

- Verwenden Sie den mitgelieferten Bügel zur Montage.
- Die Aufhängevorrichtung der Maschine muss so gebaut und bemessen sein, dass sie das 10-fache der Nutzlast aushalten kann.
- Für leicht entflammare Materialien muss ein Mindestabstand von 50 cm eingehalten werden.
- Sichern Sie die Düse immer mit einem geeignetem Sicherungsseil, dass das 10-fache der Nutzlast aushalten kann.
- Betreiben Sie die Düse in gut belüfteten Räumen.
- Achten Sie bei der Wahl des Installationsorts darauf, dass das Gerät für Wartungsarbeiten zugänglich ist.

Hängebügel

Lösen Sie die Schrauben, stellen Sie den gewünschten Neigungswinkel für die Düse ein und ziehen Sie die Schrauben wieder fest. Beachten Sie hierzu die folgende Grafik.

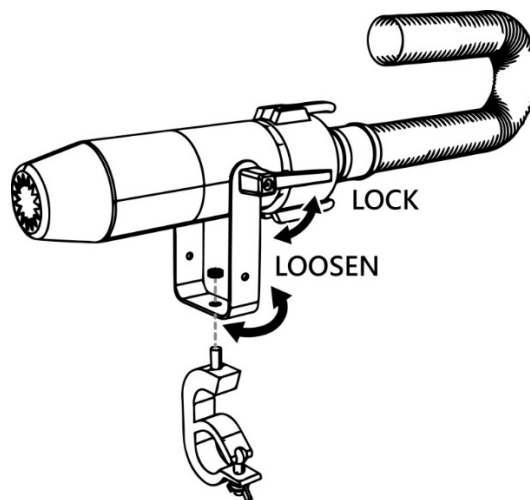

Montage

Verwenden Sie Schrauben für die Aufbaumontage oder eine Klammer für die Traversenmontage.

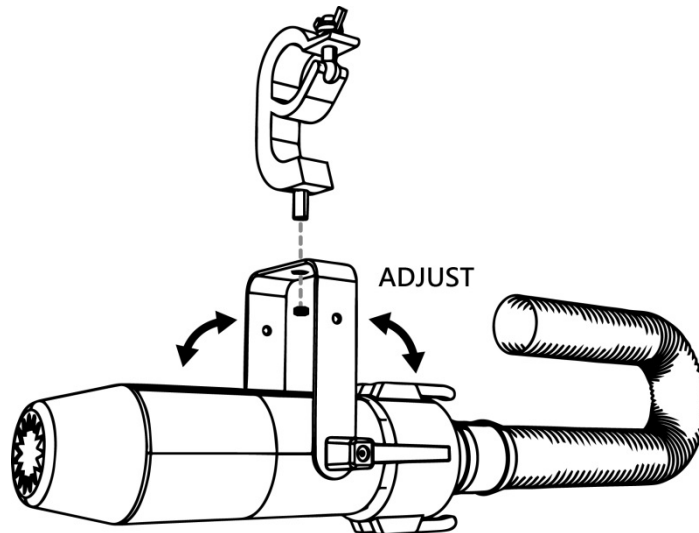

ST-10 Luftschlauchverlängerung (Zubehör)

Die maximale Schlauchlänge beträgt 20 Meter. Die folgende Grafik illustriert den Anschluss der Verlängerung.

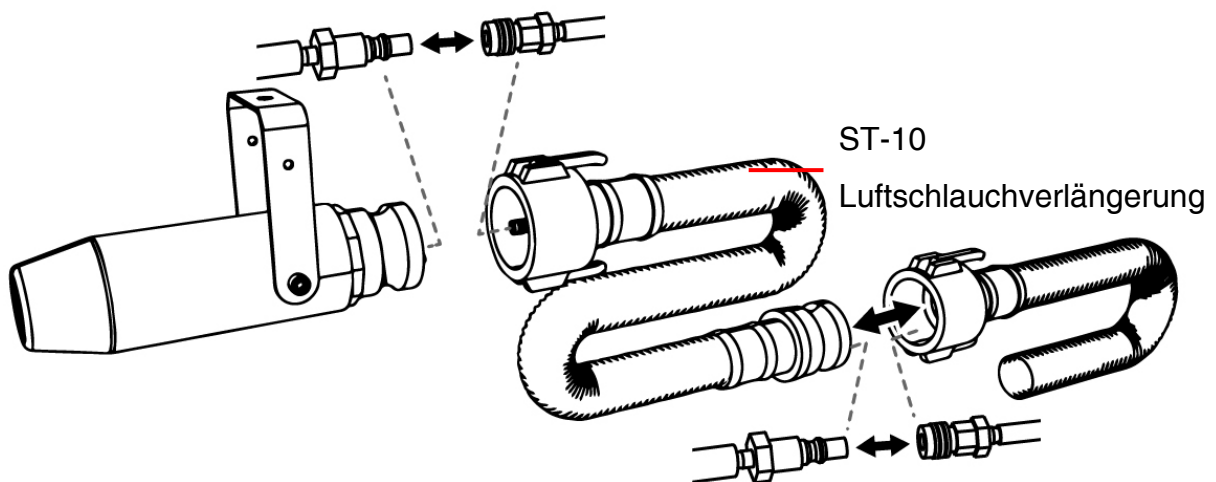

Status der W-DMX-Verbindung (Optional)

Symbol im Display	Status der W-DMX-Verbindung
●	Sender adressiert, DMX-Signal wird empfangen
◎	Sender adressiert, kein DMX-Signal
◉	Verbindung zu Sender verloren oder Verbindungsaufbau
○	Sender nicht adressiert

Schneeflüssigkeit

Verwenden Sie nur die Antari-Flüssigkeit SL-5/SL-5A oder andere hochwertige Schneeflüssigkeiten auf Wasserbasis, die von Ihrem Händler empfohlen wurden. Die Maschine wurde mit dieser Flüssigkeit getestet und kalibriert, um die beste Leistung zu erzielen. Alle anderen Schneeflüssigkeiten können Beschädigungen am Gerät zur Folge haben. Schäden, die von anderen Schneeflüssigkeiten verursacht wurden, sind von der Garantie ausgeschlossen.

Wartung

- Achten Sie darauf, dass die Maschine nicht verunreinigt wird.
- Entfernen Sie Staub von den Lüfteröffnungen mit einem Luftkompressor, Staubsauger oder einer weichen Bürste.
- Verwenden Sie zur Reinigung des Gehäuses ein angefeuchtetes Tuch.
- Spülen Sie das System unbedingt mit klarem Wasser nach jedem Betrieb, um Kondenswasser in der Pumpe oder dem Heizelement zu vermeiden.
- Es ist empfehlenswert die Maschine monatlich zu betreiben, um die beste Leistung und das beste Ausstoßverhalten zu erzielen.
- Übermäßige Ansammlungen von Staub, Flüssigkeit und Schmutz führen zu einer Verschlechterung der Leistung und zu Überhitzung.
- Spülen Sie das System unbedingt mit klarem Wasser nach jedem Betrieb und lassen Sie die Pumpe mindestens noch 1 bis 2 Minuten laufen. Dadurch werden Flüssigkeitsreste gelöst und eine Funktionsstörung beim nächsten Betrieb verhindert.

Schutzschalter zurücksetzen



Vor dem Rücksetzen ist das Gerät allpolig von der Netzspannung zu trennen.
Setzen Sie nur Sicherungen gleichen Typs und Leistung ein.

Schritt 1: Trennen Sie das Netzkabel von der Stromversorgung.

Schritt 2: Bringen Sie den Schutzschalter in die ON-Stellung

Schritt 3: Schalten Sie die Maschine für einen Funktionstest ein.

Schutzschalter

120V = 10A 250V

240V = 5A 250V

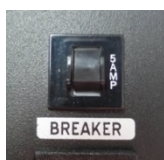

Technische Daten

S-500

Spannungsversorgung	US model : AC 100-120V, 50 / 60Hz 7,5A EU model : AC 220-240V, 50 / 60Hz 3,8A
Gesamtanschlusswert	900W
Fluidverbrauch	400 ml/min
Tankinhalt	20 Liters (5.28gal)
Kompatible Schneeflüssigkeit	Antari SLN Snow Foam Fluid Antari SLAN Snow Foam Fluid Antari SLH Snow Foam Fluid Antari SLC Snow Foam Fluid
Umgebungstemperaturbereich	5 °C - 40 °C (41 °F-104 °F)
Steuerung	DMX, Timer, manuell Funk (optional) W-DMX (optional)
DMX-Kanäle	2 Kanäle
Anschluss	Neutrik Powercon (Power) XLR 3-pol und 5-pol (DMX)
Zubehör	W-DMX-PCBR W-DMX-Modul WTR-20 Funkfernbedienung WTR-70 W-DMX und Fernbedienung WTR-80 Funkfernbedienung WTR-90 Wireless DMX SC-3 Télécommande câblée ST-10 Rallonge du tuyau 10 mètres PM-1 Pan Motor
Maße	L592 B551 H651 mm (L23,31 B21,69 H25,63 inch)
Gewicht	37,2 kg (82,01 lbs)
S-500L	
Maße	L803 B603 H651 mm (L31,61 B23,74 H25,63 inch)
Gewicht	46,4 kg (102,29 lbs)

SILENT SNOW MACHINE S-500

中文使用說明書

使用說明及安全注意事項



在使用機器以前，請仔細閱讀以下說明，此份說明書包含了如何在安全的情況下安裝使用機器，且會說明機器上所有標示的標籤所代表的意義。

如果您有任何使用上的問題，請聯繫當地的 **Antari** 經銷商尋求清楚的說明與協助。

- 保持機器的乾燥。
- 請配合接地型插座，以避免觸電的危險。
- 使用機器前，請確定使用場所的 **AC** 電源規格，與機器電壓規格是否相符。
- 拔開機器和 **AC** 電源插座時，請確認機器已關機不在使用的狀態下。
- 本產品僅限室內使用，請勿將機器暴露在雨中或潮濕的環境，如果有液體(煙霧油)翻倒或溢出，請勿連結機器與 **AC** 電源，用乾布擦拭乾淨，如果任何液體進入機器電子零件，請立即拔除插頭，並連繫當地的 **Antari** 經銷商。
- 本機器不含任何用戶拆解和自行維修或修改的零件在內，請勿嘗試自行維修或改裝機器，未經授權的技術人員，可能導致機器故障或永久損壞。
- 機器限成人操作，請勿在無人值守時讓機器運作。
- 在通風良好的地方安裝使用機器，機器周邊至少應保留 **50** 公分的空間。
- 請勿添加任何易燃物品進入機器。
- 操作機器時請確認周邊沒有任何易燃的材料。
- 為確保機器使用壽命，請使用 **Antari** 品牌的雪花水，添加其他液體可能會導致機器故障。
- 如果機器出現故障，請拔下機器插頭，立即停止工作。並請連繫您當地的 **Antari** 經銷商。
- 運送機器以前，請確認機器的油箱已完全清空。
- 雪花水不能食用，吞食雪花水可能導致損壞健康的風險，請將雪花水存放在室內安全的地方。如果碰觸到眼睛或誤吞食，請立即尋求醫生的協助。

包裝內容

在收到機器後，請立即小心地打開包裝紙箱，檢查所有內容，以確保所有零配件都有齊全收到，並處於良好的狀態。如果有任何部件因運輸過程出現損壞或缺少，請立即連絡經銷商，並以原包裝退回檢查。

內容包括:

- 1 台 S-500 雪花機
- 1 條 電源線
- 1 本 使用手冊
- 1 條 油管
- 1 個 20 公升油桶
- 1 條 10 米的伸縮軟管(S-500) / S-500L 為 20 米
- 1 個 噴頭

機器尺寸

型號：S-500



型號：S-500L



機器外觀概述



S-500 控制面板

- 復歸式電源斷路器
- 主電源開關
- 無線訊號接收器
- 控制面板



油桶容量：20 公升

噴頭

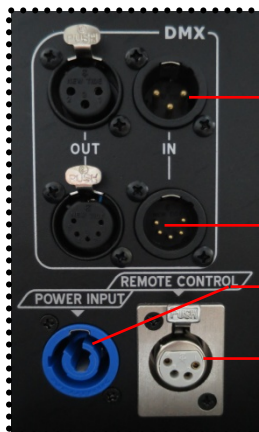

XLR 3-Pin DMX 連接座

XLR 5-Pin DMX 連接座

Neutrik PowerCon 電源連接座

SC-3 控制器連接座 (選配)



PM-1 搖頭旋轉台 (選配)

設定安裝

步驟 1: 將機器平放於平坦的表面，機器周圍至少應保留 50 公分的空間。

步驟 2: 將 SL-5N/SL-5AN 雪花水注入機器所附的油桶，並注意不要拗折到油管。

步驟 3: 將機器連接電源。連接之前，請確認機器背後技術標籤上所標示要求功率，是否與電源相符。



請務必將機器連結到有保護的電路，並確保有正確地接地，以避免觸電的危險。

步驟 4: 啟動機器，按下控制面板上的[VOLUME]/[DOWN]按鍵，使機器開始輸出雪花。

步驟 5: 需關閉本機時，按下[STOP]按鍵並將電源街頭轉到 **OFF** 的位置。

操作

控制面板操作

使用機器所搭載的數位控制面板進行操作控制。

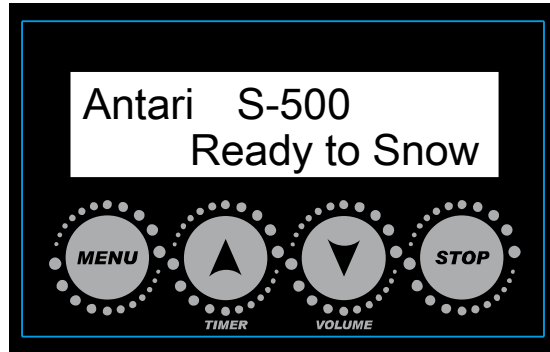

按鍵	功能
[MENU]	瀏覽設定清單
[UP]/[TIMER]	增加數值/啟動 定時模式
[DOWN]/[VOLUME]	減少數值/啟動 輸出量模式
[STOP]	關閉 定時/輸出量模式, 離開設定清單

語言設定

欲更改操作介面的語言設定，在啟動機器之前，按住[MENU]再啟動機器，直到 LCD 螢幕閃兩下。閃了兩下之後，按下[MENU]來選擇語言：English (英文) 與中文，再按下[STOP] 來紀錄選擇的語言選項。

控制清單

Timer Interval XXX Sec	設置定時模式下的雪花輸出間隔時間，範圍是 15 至 360 秒。
Timer Duration XXX Sec	設置定時模式下的雪花持續輸出的時間，範圍是 5 至 120 秒。
Timer Output XXX %	設置定時模式下的雪花輸出量，範圍是 1 至 100%。

Volume Output XXX %	設置輸出量模式下的雪花輸出量，範圍是 1 至 100%。
Fan Speed XXX %	設置風扇轉速，範圍是 20 至 100%。
DMX-512 Address: XXX	設置 DMX/W-DMX 從 1 至 511 的位址(本機佔用 2 頻道)。
W-DMX Power XX	啟動/關閉 W-DMX 功能
W-DMX Reset XX	離線 W-DMX 連接(換控台時，重抓 W-DMX 訊號)
Wireless XX	啟動/關閉 W-2 無線控制器
Wireless Register Up:Pair Down:Del	配對/取消配對 W-2 無線控制器 *當無線功能啟動時，不會顯示此選項。
Run Last Setting XX	啟動/關閉 前次使用最後設定功能。

DMX 連接 Pin 點說明

本機可提供 3 PIN 或 5 PIN XLR 的 DMX 連接選擇。下為 PIN 的接點說明：

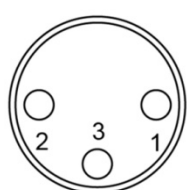

3 Pin XLR

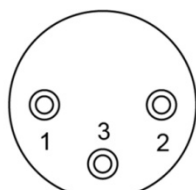

5 Pin XLR

Pin	功能
1	接地
2	數據-
3	數據+

DMX 通道功能

建立 DMX 連接 – 將機器連結到 DMX 控制器或 DMX 鏈中的機器之一。本機採用的 DMX 連接座是 3-pin 與 5-pin XLR 連接座，該連接座位於機器背面。



設置 DMX 位址 – 透過控制清單來設置 DMX 位址。本機佔用 2 個控制通道，起始位址被定義為第一頻道，從該機器將回應到控制器。請仔細檢查，是否有重疊的控制通道以確保控制功能與正常。

v

DMX 通道功能

通道 1	DMX 數值範圍	功能
雪花輸出量	0 – 5	關閉
	6 – 255	閉啟，輸出量 1 – 100%
通道 2	DMX 數值範圍	功能
風扇轉速	0 – 5	風扇轉速 20%
	6 – 255	風扇轉速 21 – 100%

WTR-20 無線控制模組使用說明 (選配)

*W-2 無線發射器

- 發射器：使用 27A 12V 電池

- 接收距離：在無障礙物的開放空間，有效距離為 50 公尺。
實際狀況根據障礙物多寡，保守距離約為 10-25 公尺。
- W-2 無線發射器配有 4 個按鈕，可以用來啟動、關閉及調整雪花量大小。



W-2 無線發射器

***無線接收器**

- 接收器在經過測試後，會固定在 S-500 的機器面板上，請勿嘗試將它拔除。



無線接收器

按鈕	功能
[A]	啟動雪花量輸出
[B]	關閉雪花量輸出
[C]	增加輸出量
[D]	減少輸出量

W-2 無線發射器配對說明

發射器可與接收器對頻及取消對頻。每個接收器可以與最多 10 組發射器對頻。請按照以下圖中的步驟來取消與對頻無線發射器：

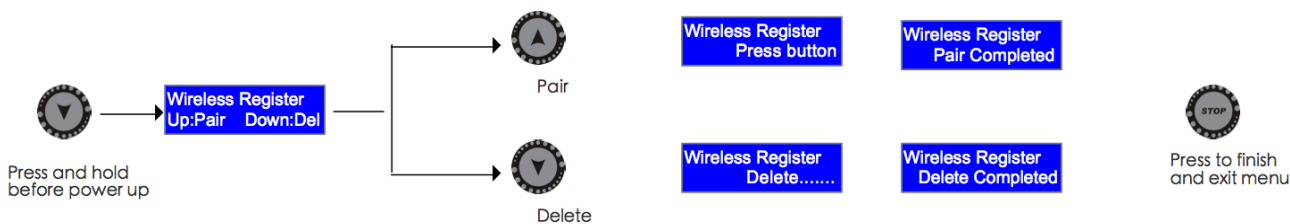

請注意: 只有當無線功能啟動時，才會顯示無線發射器對頻的選單。

更換 W-2 無線發射器電池

如果無線控制器的有限控制距離縮短，可能是電池的電力不足，需要更換。請將 W-2 發射器背後的三個螺絲旋開，打開背蓋，使用同樣是 27A 12V 的電池更換。

SC-3 有線控制器操作 (選配)

使用控制器操作機器時，請將 SC-3 控制器連結位於機器背面的 4 Pin 麥克風插座。SC-3 配有 3 個按鈕及 2 個旋鈕，可控制啟動/關閉機器、設定及調整風扇轉速及雪花輸出量。



按鈕/旋鈕	功能
[VOLUME]旋鈕	調整幫浦輸出量
[FAN]旋鈕	調整風扇轉速
[PRIMING]黃色按鈕	將幫浦輸出量與風扇轉速設定為最大
[POWER]紅色按鈕	開啟/關閉 SC-3 控制器
[MAX FAN]綠色按鈕	將風扇轉速設定為最大

請注意:

左側黃色的[PRIMING]按鈕主要是機器啟動時使用，換一個新的油桶或是添加雪花水後，幫浦可能因為油管中有空氣而無法順暢的運作，此時可以使用此功能將風扇與幫浦的輸出量設定到最大，藉此將油管中的空氣排出。右側綠色的 [MAX FAN]按鈕是當需要清除噴嘴殘留的雪花水時使用。兩個按鈕按下後，會取代[VOLUME]旋鈕的輸出量設定。

實體安裝

注意事項

- 使用安裝支架或吊掛夾具來安裝噴頭。
- 確認安裝處、固定接頭以及吊掛索具可以支撐噴頭 10 倍以上的重量。
- 確認周邊沒有任何易燃的材料。
- 安裝噴頭時，請務必使用可以支撐噴頭 10 倍重量以上的安全繩索。
- 請將噴頭安裝在通風良好的地方。
- 在選擇噴頭的安裝地點時，請將更換噴頭及定期維護的方便性納入考量。

可調式安裝支架

鬆開螺絲以調整安裝支架，將噴頭調整想要的角度後，將螺絲鎖緊便完成調整步驟。調整步驟如下圖所示。

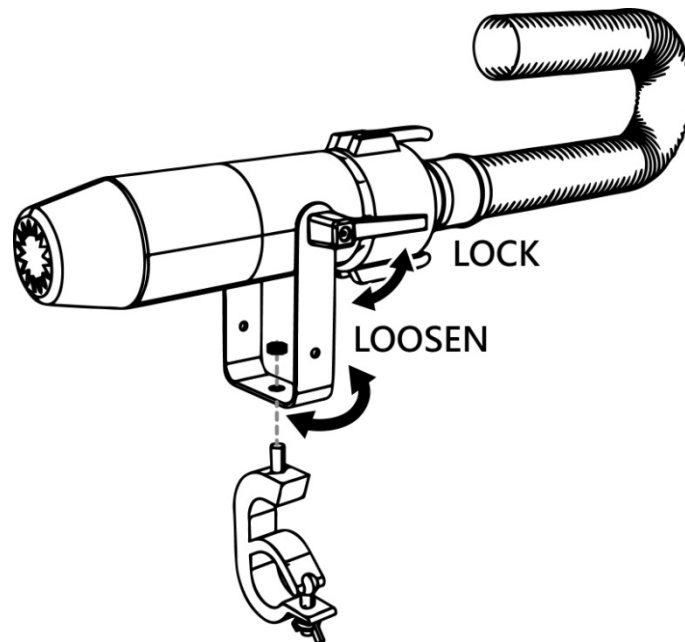

安裝

使用螺絲進行表面安裝或使用夾具安裝在衍架上。

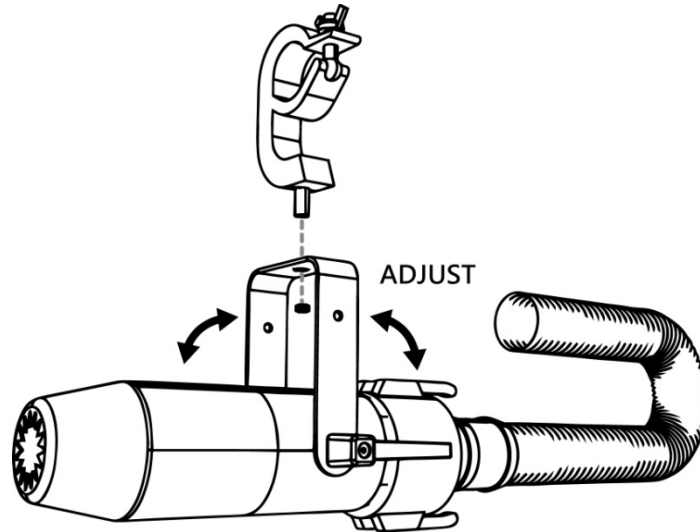

ST-10 / 10 米延長管 (選配)

伸縮軟管最長為 20M。將噴頭與延長管連接的步驟，如下圖所示。

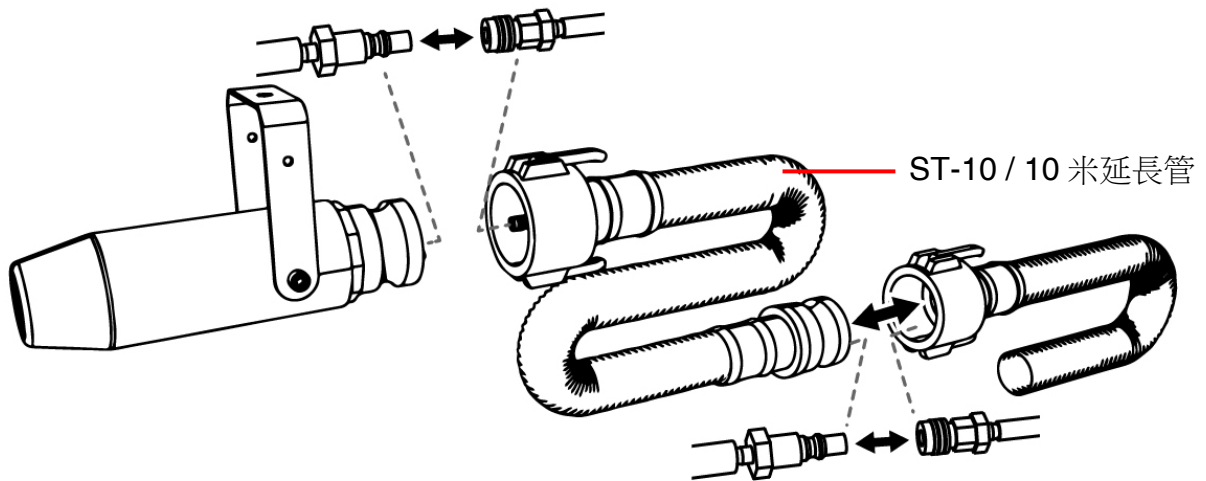

W-DMX 連接狀態 (選配)

LCD 螢幕上所顯示的符號	W-DMX 連結狀態
●	無線發射器已對頻，接收到 DMX 訊號
◎	無線發射器已對頻，但沒有 DMX 訊號
⊙	無線發射器連接遺失 / 正在與發射器連接
○	沒有對頻任何無線發射器

雪花水的使用

S-500 雪花機僅能使用 SL-5N/SL-5AN 雪花水。機器使用 SL-5N/SL-5AN 雪花水進行測試與校正，使用此雪花水將產生最佳的雪花效果。若使用其他的雪花水，將導致機器故障並使保固失效。

維護與保養

- 請保持機器清潔，不要讓機器髒汙。
- 可以使用空氣壓縮機、吸塵器或軟刷除去機器上的灰塵。
- 機殼可使用濕布擦拭。
- 建議每月至少讓機器運轉一次，以保持機器處於最佳的性能和輸出條件。
- 機器上過多的灰塵、液體殘餘累積的髒污會降低機器工作性能，導至散熱不良。
- 每次使用完畢儲藏前，請注入清水至油桶中並啟動機器讓幫浦運轉 1~2 分鐘，讓清水帶出才留在馬達及前端噴嘴中的雪花水，以清潔機器卻保機器更長的使用壽命。

重新設置復歸式電流斷路器



重新設置復歸式電流斷路器之前，請關閉電源，限用同樣類型與等級的復歸式電流斷路器。

步驟 1: 關閉電源

步驟 2: 將復歸式電源斷路器按至 ON 的位置

步驟 3: 開啟機器測試

復歸式電流斷路器

120V = 10A 250V

240V = 5A 250V



規格資料

S-500

- 電壓 美規 : AC 100-120V, 50 / 60Hz 7.5A
歐規 : AC 220-240V, 50 / 60Hz 3.8A
- 額定功率 880 瓦
- 耗油量 400 毫升/分鐘
- 油桶容量 20 公升(5.28 加侖)
- 適用雪花水 Antari SL-20N 雪花水(水性)
Antari SL-20AN 高揮發性雪花水(水性)
- 運作時間 (最大輸出量下) 50 分鐘
- 適用環溫 5 °C - 40 °C (41 °F-104 °F)
- 控制方式 DMX512, 定時控制, 手動控制
無線控制 (選配)
無線 DMX (選配)
- DMX512 頻道 占用 2 頻道
- 連接座 Neutrik Powercon(主電源)
XLR 3-pin 及 5-pin (DMX)
- 選擇性配件 W-DMX-PCBR 無線 DMX 控制模組
WTR-20 無線控制模組
WTR-70 無線 DMX 及無線控制模組
WTR-80 無線控制模組
WTR-90 無線 DMX 控制模組
SC-3 有線控制器
ST-10 10 米延長管
PM-1 旋轉台
- 尺寸 長 592 寬 551 高 651 mm
(長 23.31 寬 21.69 高 25.63 inch)
- 重量 37.2 公斤 (82.01 lbs)

S-500L

- 尺寸 長 803 寬 603 高 651 mm (長 31.61 寬 23.74 高 25.63 inch)
- 重量 46.4 公斤 (102.29 lbs)



For current product information visit Antari at: www.antari.com
For information requests please contact us at: sales@antari.com



C08S50006

www.antari.com



G5 Short guide

Pinout

Pin number	Function	Comment
J1:1	GND	
J1:2	Data - / RxD	RxD if J3:12 is connected to 3.3V, internal pulldown
J1:3	Data + / TxD	RxD if J3:12 is connected to 3.3V, internal pulldown
J1:4	Function switch	Pull up to 3.3V internally
J1:5	OEM LED	3.3V when On
J1:6	5V, 5-15V, 5-26V	Depending on card model
J1:7	GND	
J1:8	3.3V	Different compared to G4
J1:9	Reception Indicator / Mode	Different compared to G4
J1:10	Direction	For TRX cards

J3 is only for cards with -SPI extension

J3:1	Reset	
J3:2	RX_NOT_TX	Output, High as RX, low as TX
J3:3	Reserved	N/C internal use
J3:4	Reserved	N/C internal use
J3:5	Slave IRQ	IRQ signal when radiocard is SPI slave, not implemented
J3:6	Overlay CS	CS Signal for overlay, active high
J3:7	SLAVE CS	CS Signal when radiocard is SPI slave, not implemented
J3:8	SCK	Serial Clock signal
J3:9	MISO	Master In, Slave out signal
J3:10	MOSI	Master Out, Slave in signal
J3:11	RS485 DIR	Direction for RS485 driver
J3:12	RS485 DISABLE	Connect to 3.3V when internal RS485 driver should be turned off



Information for migrating from G4 to G5

PLEASE NOTE:

- Pin 6 can handle 5 to 15V input on all receiver cards
A40895G5 and A40896G5SPI
- Pin 6 can handle 5V input on following transceiver cards
A40890G5 and A40891G5SPI
- Pin 6 can handle 5 to 26V input on following transceiver cards
A40890G5SPI
- Pin 8 can only be connected to 3.3V
- Connect only one power source to the card
- OEM LED output 3.3V when the LED should be on, adjust resistor to give enough current to the LED, maximum output current is 0.5mA
- Pin 9 does not indicate MODE on the receiver, on receiver it is indicating reception
- Shutdown voltage:
To ensure stable operation, the voltage need to be according to the pinout list. But the card may be operational all the way down towards 1.5V, to ensure that the cards is disabled, power need to be reduced to 0V



Transceiver cards

IMPORTANT DMX direction for cards

All transceiver cards can operate as transmitter or receiver, by setting the voltage on pin 10 in the following 3 configurations

Pin 10 voltage	Function
GND	Transmitter (like G4 type O cards)
3.3V (Open)	Receiver (like G4 type O cards)
1.65V	Transmitter or receiver (like G4 type R cards) Direction is fetched from non-volatile storage; direction is changed if the button (pin 4) is connected to GND during power up To accomplish this, it is easiest to use two 4.7kOhm resistors, put one 4.7kOhm from pin 8 (3.3V) to pin 10 and one 4.7kOhm resistor from pin 7(GND) to pin 10.

OEM LED indication

Transmitter card



On 900ms / Off 100ms = no DMX present



Continuously On = DMX present



On 100ms / Off 100ms = linking receivers



On 500ms / Off 500ms = unlinking all receivers

Receiver card

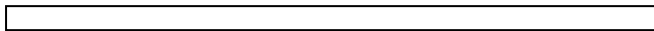

Continuously Off = not assigned to a transmitter



On 900ms / Off 100ms = assigned to a transmitter, but no DMX present



Continuously On = assigned to a transmitter and DMX present



On 100ms / Off 100ms = link to transmitter lost or linking to transmitter



MODE LED indication

Transmitter card



Continuously On = G4S mode

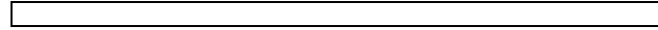

Continuously Off = G3 mode

Receiver card



After a low pass filter ¹

The signal has a 1s period, that goes low in 100ms steps to indicate reception rate:

100% reception: High

90% reception: 900ms high, 100ms low

60% reception 600ms high, 400ms low

1) The low pass filter should filter pulses that are up to 50 us long. Pin 9 can drive up to 0.5mA and for filter purpose, there is a 330ohm resistor on the PCB between the driver and the pin.

There will be a pulse for each received radio package, if the pulse is high or low depends on the current signal level, there will be an error of up to 2 pulses for each second, so the error is neglectable if the reception is measured with pulse counting.



LED Overlay Interface, G5 cards

For the G5 cards with SPI functionality (two pinheaders).

It is possible to implement a display interface similar to the one used on the W-DMX BlackBox/WhiteBox range.

The overlay interface consists of an SPI interface that shifts out data for the LEDs as described below. To avoid flicker a latched shift register is recommended.

The SPI speed is 2.5MHz and Overlay CS is pulled high before the output start and pulled low after the SPI output has ended, SCK and MOSI is output signals.

LED order

Name	Bit	Text	Color	Description
Power	0	PWR	Blue	Power, blinking in control mode
RDM	1	RDM	Green	RDM on/off
Green of Mode LED	2	Mode	Green	Mode indicator, part of a RGB LED
Red of Mode LED	3	Mode	Red	Mode indicator, part of a RGB LED
Blue of Mode LED	4	Mode	Blue	Mode indicator, part of a RGB LED
2 Universe	5	UNIV	Green	Is receiving a 2 universe link
Link	6	LINK	Green	Link established
Data	7	DATA	Green	DMX Data present
Transmit Mode	8	TX	Green	Radio Transmitter
Receive Mode	9	RX	Green	Radio Receiver
Reserved	10			
Signal 1	11		Red	Signal Strength
Signal 2	12		Yellow	Signal Strength
Signal 3	13		Green	Signal Strength
Signal 4	14		Green	Signal Strength
Signal 5	15		Green	Signal Strength